

Parts needed to assemble the HR-LINE extrusion.



Extrusion (A)



Gland (B)



End Cap (C)



LED tape in silicone sleeve (D)



Base foam (E)



Cover (F)

Tools needed for mounting:

- drill
- mounting adhesive
- silicone

NOTE! All LED strips must be connected to a 12V or 24V power supply.

IMPORTANT: The manual presents the simplest mounting procedure.
More mounting procedures and related accessories can be found at klusdesign.com

1. Drill a hole in the extrusion (A) to mount the gland (B) and connect power.
[Download the gland mounting instructions](#) at klusdesign.com

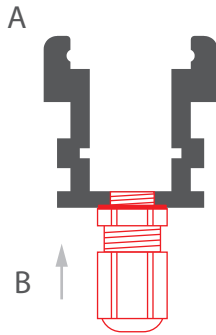

2. Mount the LED strip (D) in the extrusion. Feed LED power through the gland (B) and tighten it. Secure the LED strip against shifting and humidity using silicone. Insert the end cap (C) and the cover (F).
[Download the extrusion sealing instructions](#) at klusdesign.com.

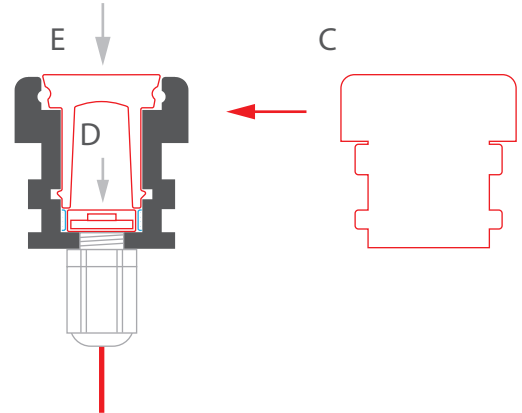

3. Feed power. Place the base foam (E) in the mounting channel. The pad must be approx. 2-5 cm shorter than the mounting channel to accommodate the gland. Spread mounting adhesive on the walls of the mounting channel.

cross-section

top view

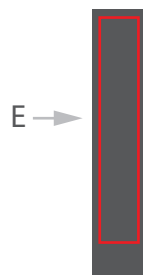
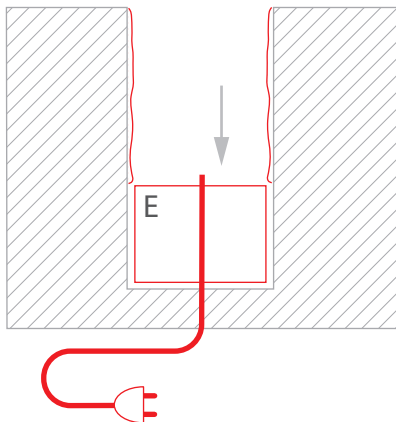

4. Connect power. Mount the extrusion in the mounting channel.

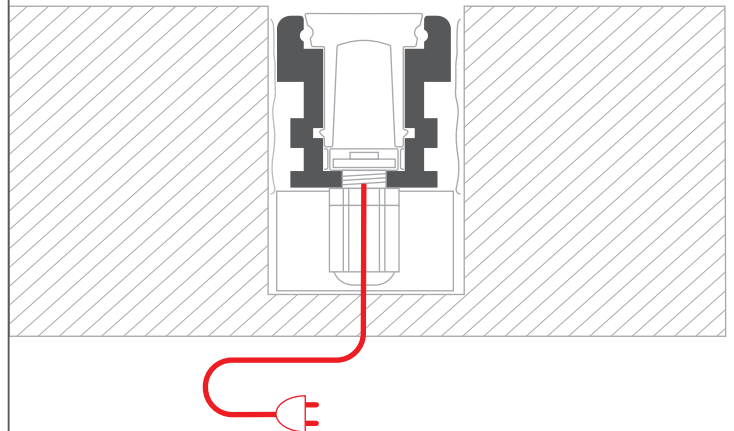

1. Degrease and wipe all elements of the extrusion.

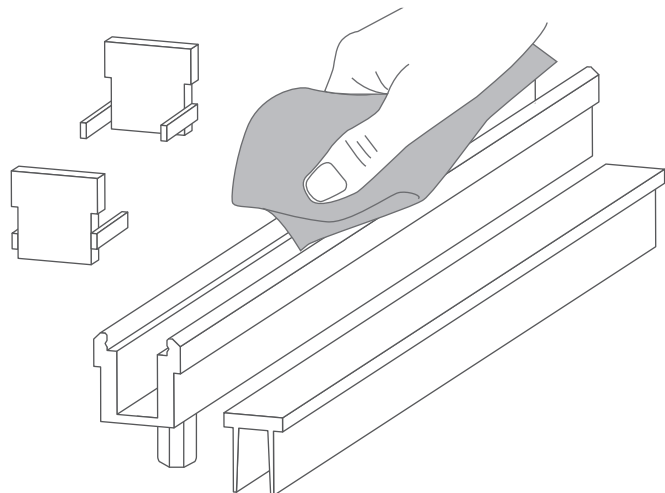

2. Degrease and wipe the sleeve.

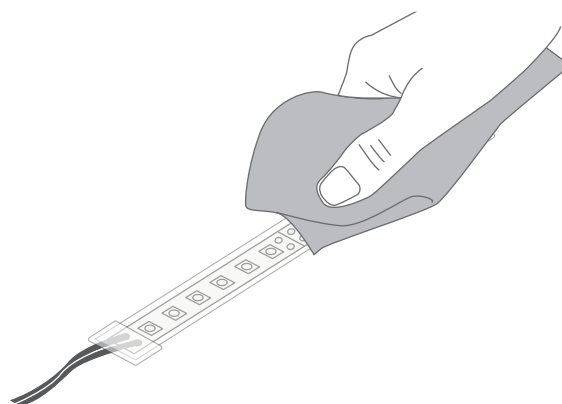

3. Cut the cover using a power saw. It should be reduced by 1.5 mm on each side. For fixtures shorter than 1 m, it can be shortened by 1 mm on each side.

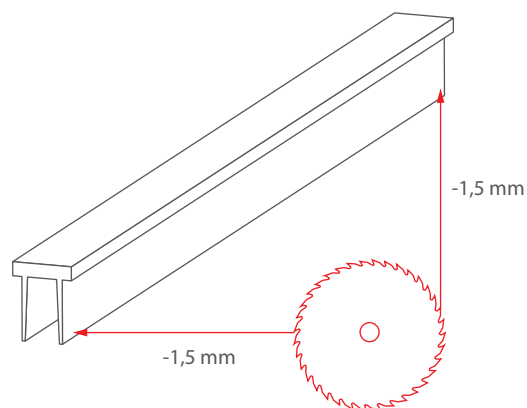

4. Cut the wings of the cover at a 45° angle.

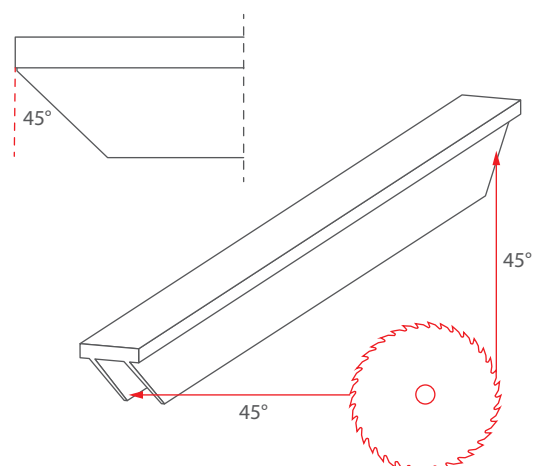

5. Apply a small layer of silicone to the bottom of the extrusion.

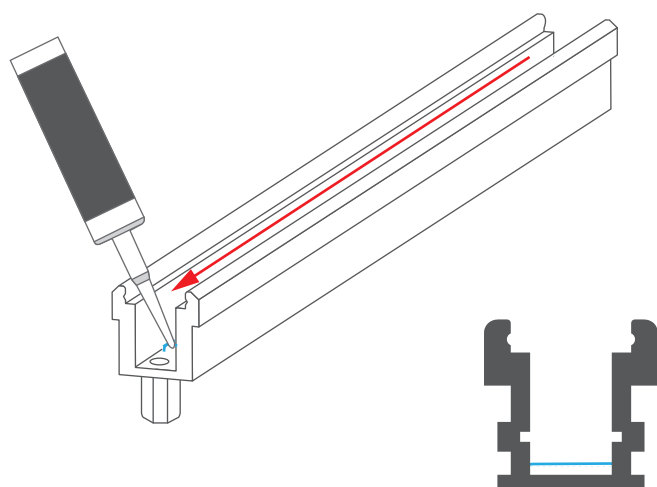

6. Place the LED strip in the extrusion. Lead the power cable through the gland and tighten it. [Instructions for assembly of the gland](http://www.klusdesign.com) can be downloaded at [klusdesign.com](http://www.klusdesign.com).

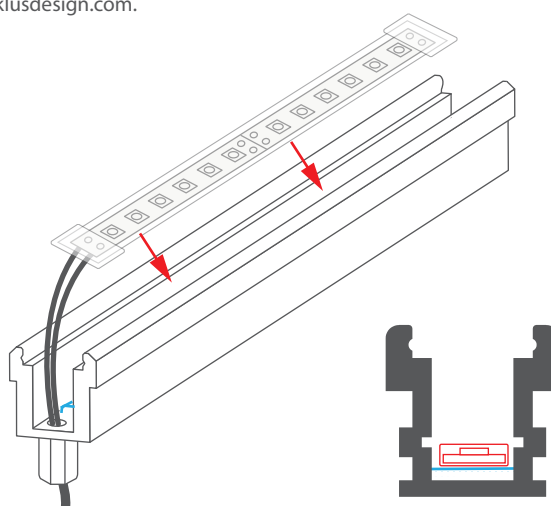

7. Place a small amount of silicone along the two edges of the sleeve with the LED strip.

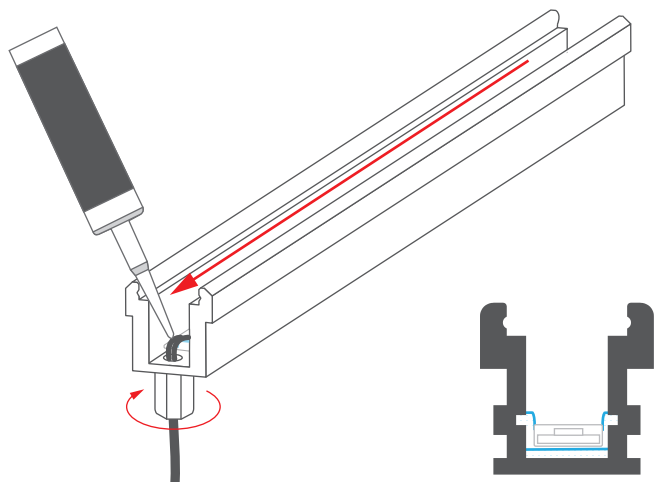

8. Insert silicone into the tightened gland to seal it.

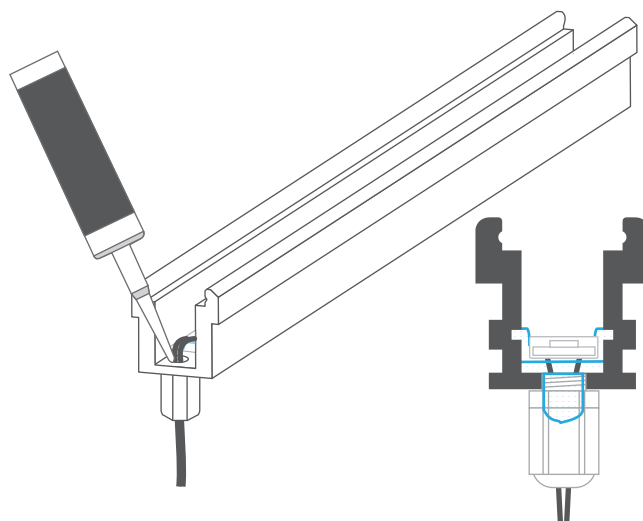

9. Collect excess silicone. We recommend using a piece of PVC cut in the shape of the letter "T".

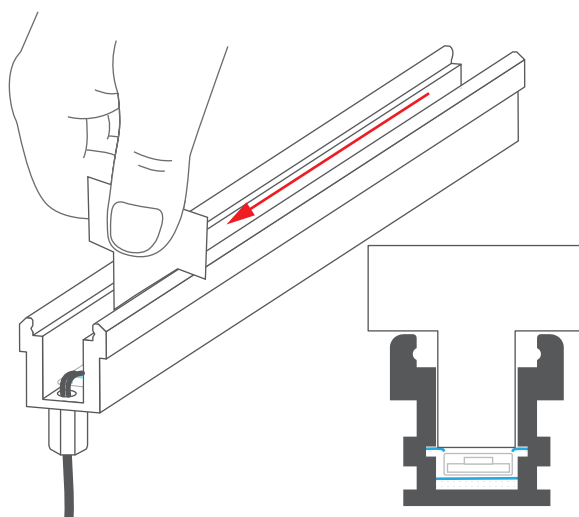

10. Place more silicone at the ends and above the gland. The shape of the cork formed must allow for the assembly of the previously cut cover.

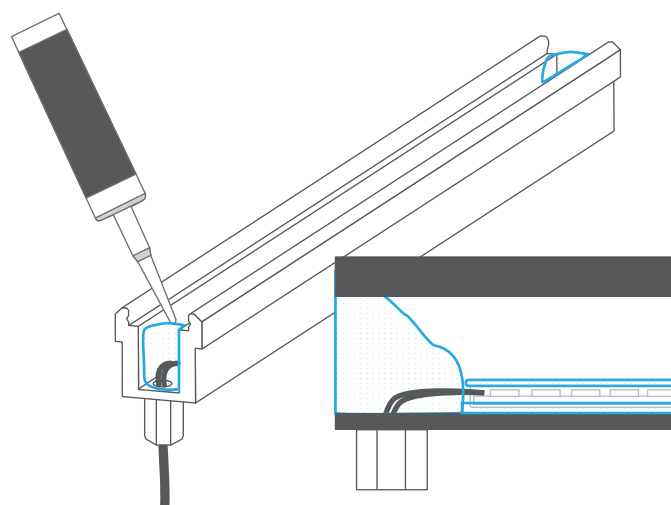

11. Put a small amount of silicone on the upper shelves of the extrusion.

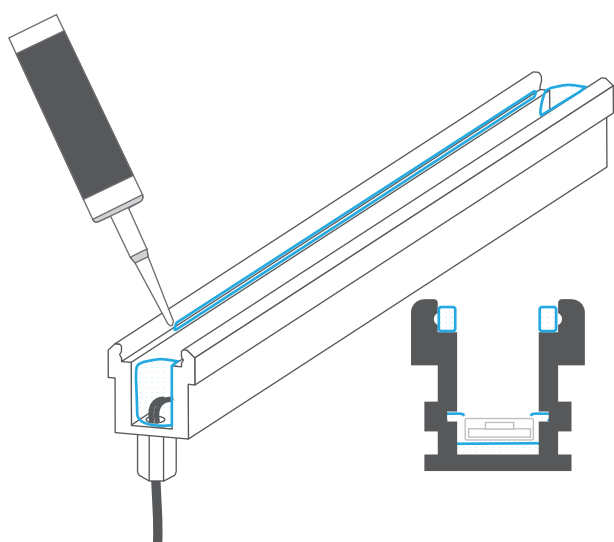

12. Insert the cover into the extrusion. Small quantities of silicone might come out at this stage.

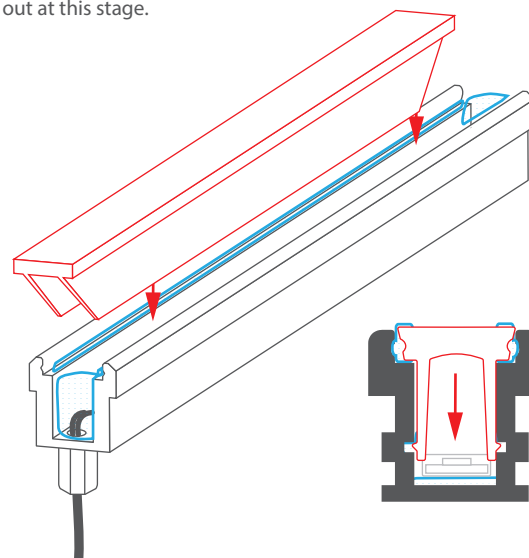

13. Insert the end caps into the extrusion with glue.

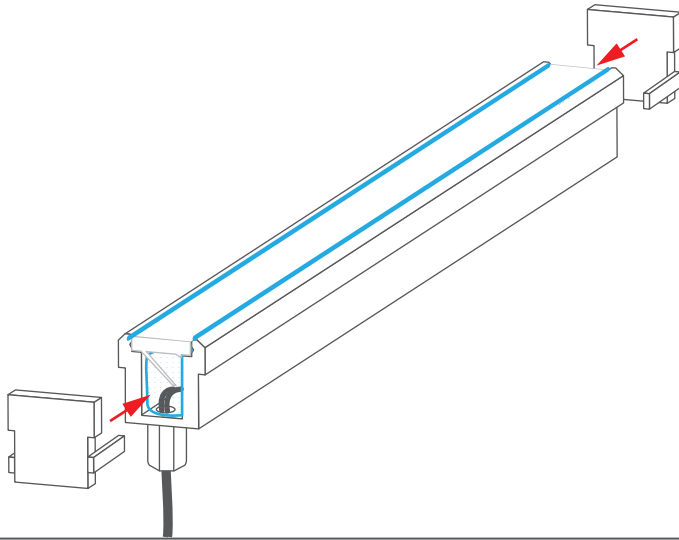

14. Insert additional silicone into the gaps with the end caps to tightly seal the fixture.

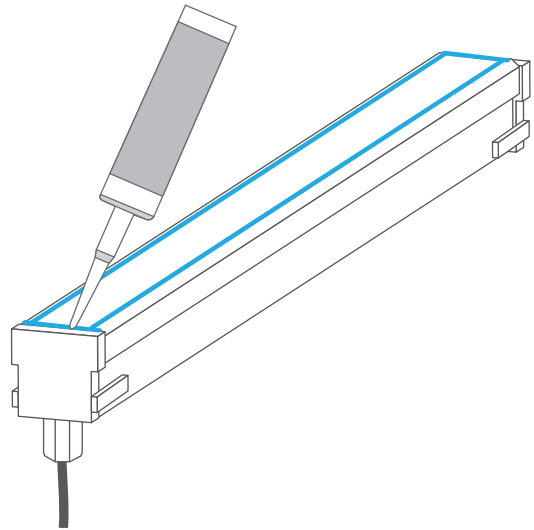

15. Wipe the fixture thoroughly to remove any excess silicone.

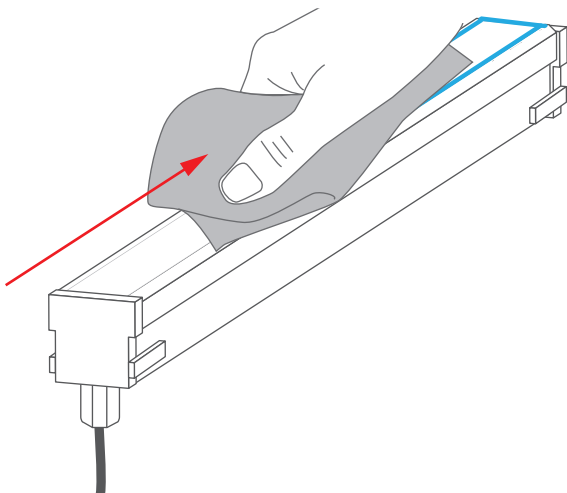

1. Degrease and wipe all elements of the extrusion.

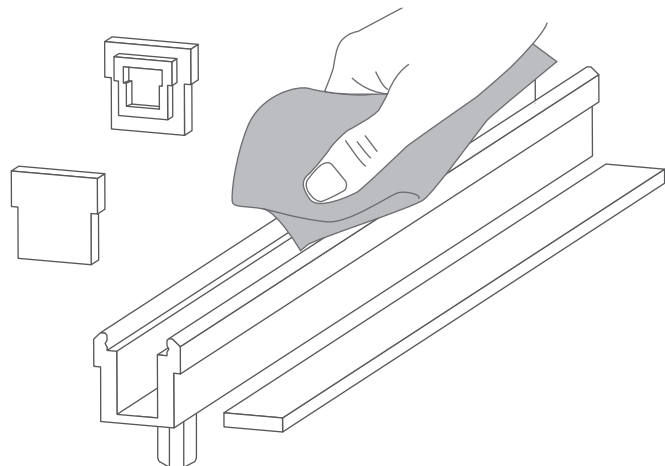

2. Degrease and wipe the sleeve.

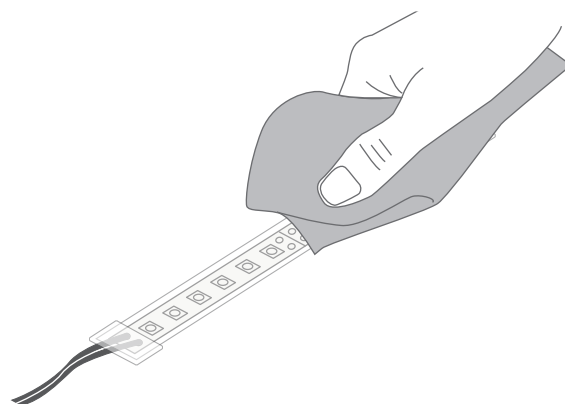

3. Cut the cover using a power saw. It should be reduced by 1.5 mm on each side. For fixtures shorter than 1 m, it can be shortened by 1 mm on each side.

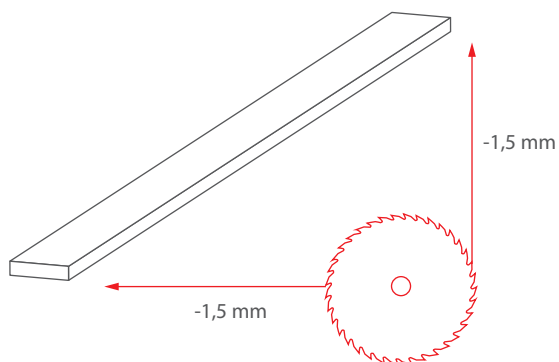

4. The cover should be mounted from the side that adheres to the profile.

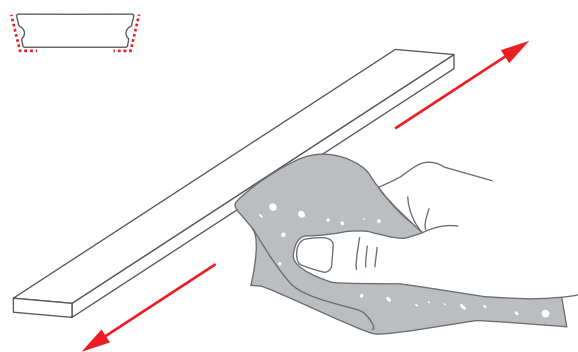

5. Apply a small layer of silicone to the bottom of the extrusion.

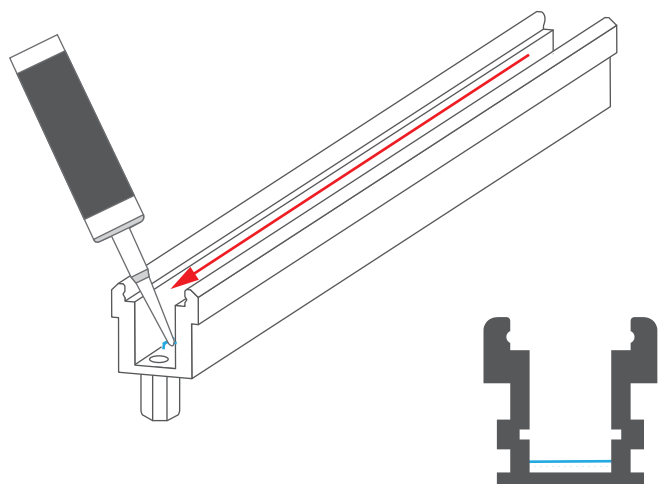

6. Place the LED strip in the extrusion. Lead the power cable through the gland and tighten it. [Instructions for assembly of the gland can be downloaded](http://klusdesign.com) at klusdesign.com.

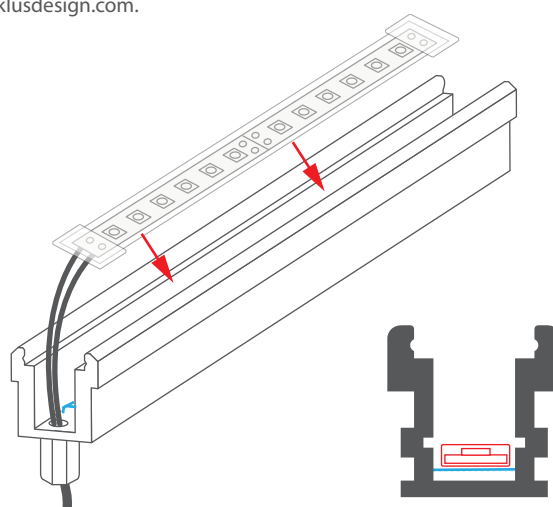

7. Place a small amount of silicone along the two edges of the sleeve with the LED strip.

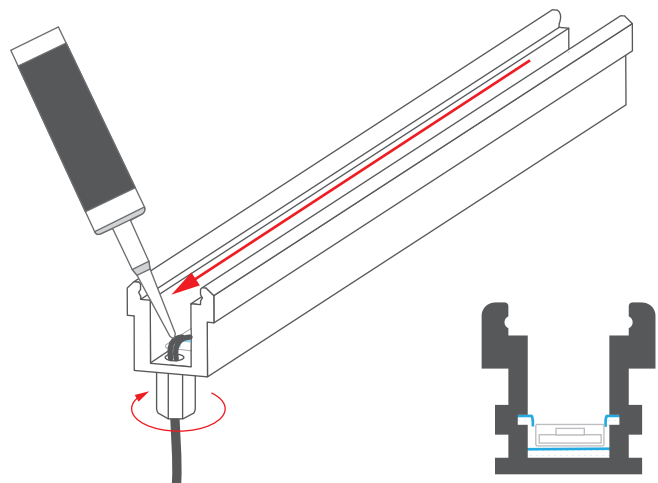

8. Insert silicone into the tightened gland to seal it.

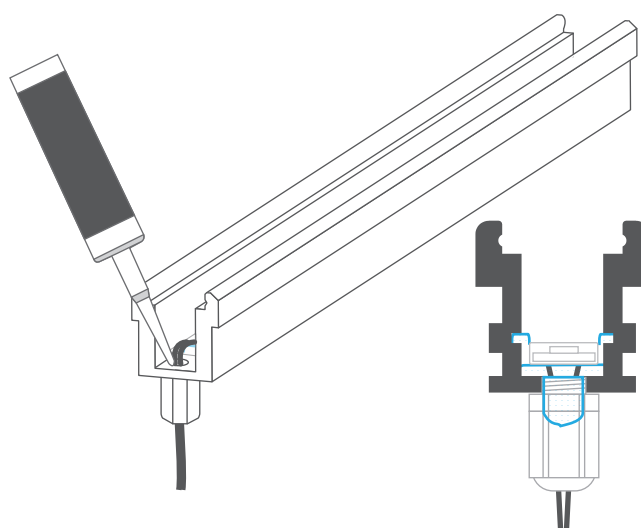

9. Collect excess silicone. We recommend using a piece of PVC cut in the shape of the letter "T".

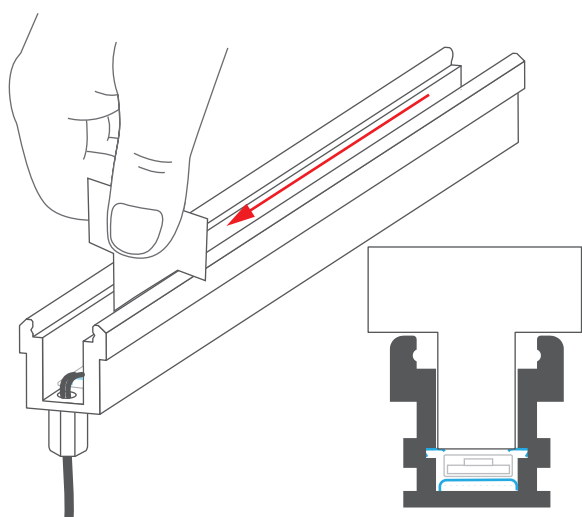

10. Adhere end caps to the extrusion using mounting adhesive.

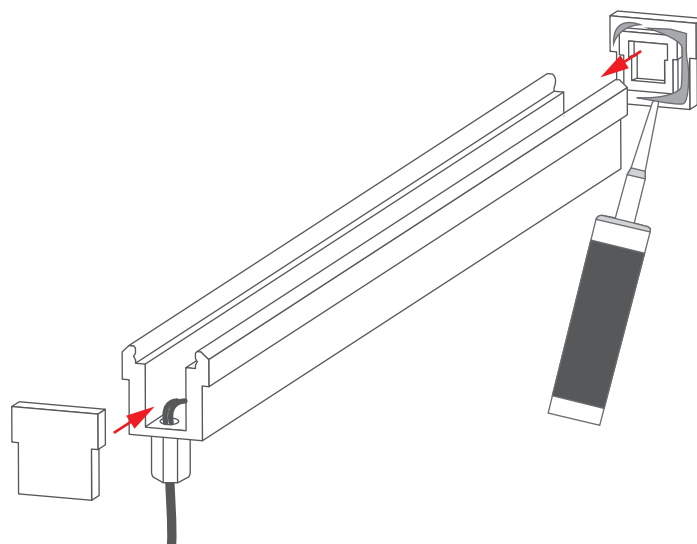

11. Place more silicone at the ends of the extrusions creating plugs at the ends and above the gland. The shape of the cork formed must allow for the assembly of the previously cut cover.

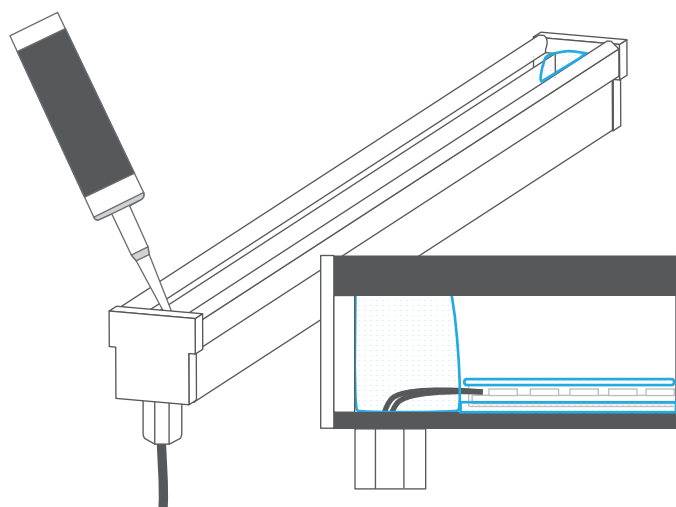

12. Put a small amount of silicone on the upper shelves of the extrusion.

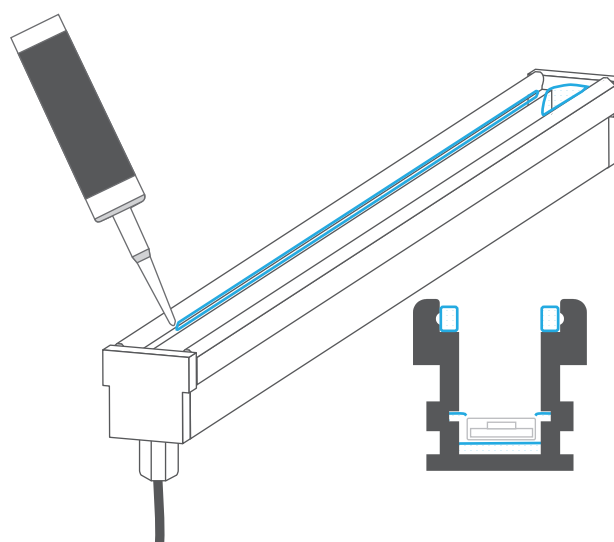

13. Insert the cover.

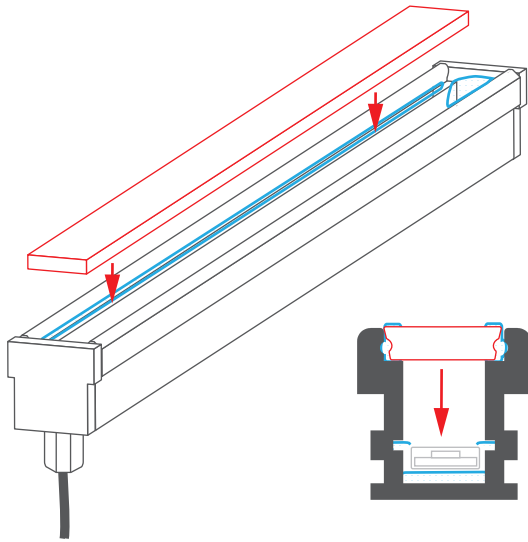

14. Insert additional silicone into the gaps with the end caps to tightly seal the fixture.

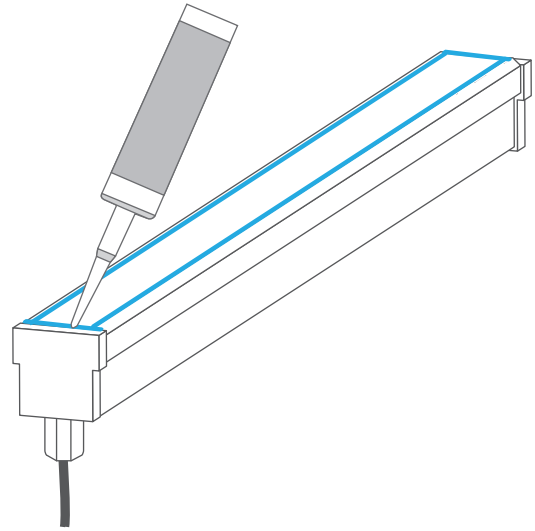

15. Wipe the fixture thoroughly to remove any excess silicone.

